

# Logic Gates

Networks and Embedded Systems

First Grade Level

Wolfgang Neff

# Logic Gates (1)

- Families of Logic Gates

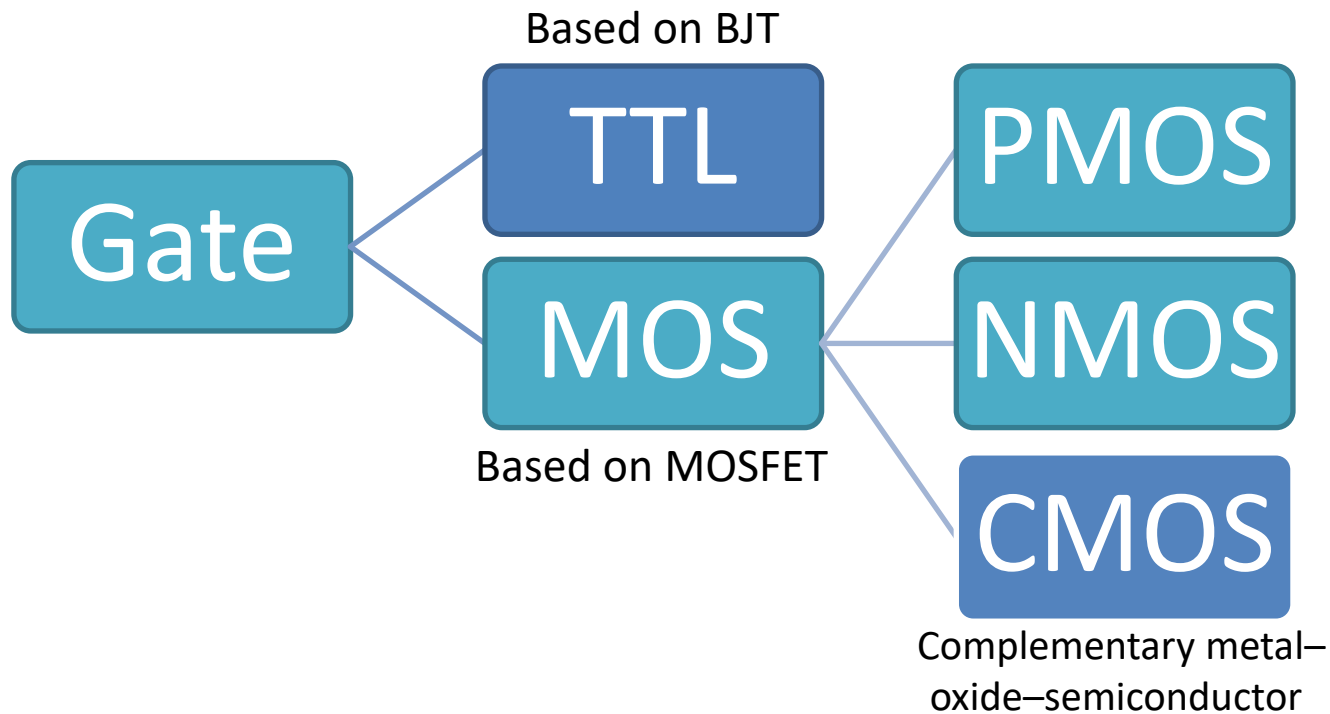

# Logic Gates (2)

- Transistor-Transistor-Logic
  - TTL circuits operate with 5 V supply power
  - H and L are defined as voltage ranges
  - Input and output ranges differ

TTL Signal	Input	Output
L	0 V ... 0,8 V	0 V ... 0,4 V
H	2 V ... 5 V	2,4 V ... 5 V

# Logic Gates (3)

- Transistor-Transistor-Logic (continued)
  - Signal levels

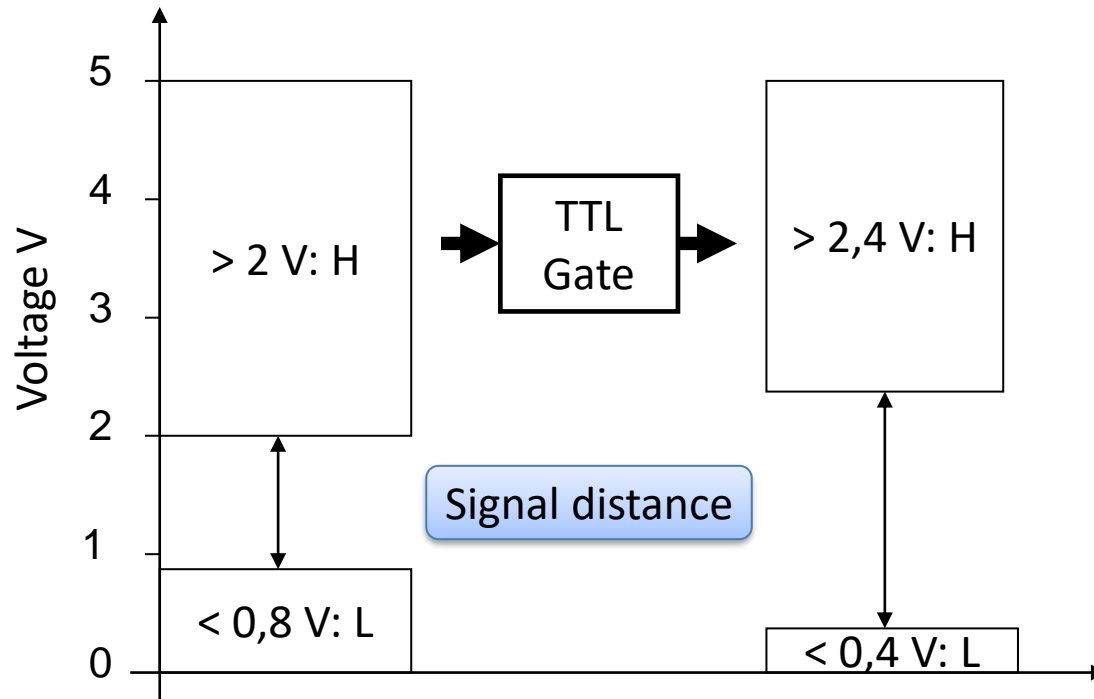

# Logic Gates (4)

- Transistor-Transistor-Logic *(finished)*
  - TTL gates are found in the 7400 series

IC	Gate	Number	Lines	IC	Gate	Number	Lines
7408	AND	4	2	7400	NAND	4	2
7411	AND	3	3	7410	NAND	3	3
7421	AND	2	4	7420	NAND	2	4
7432	OR	4	2	7402	NOR	4	2
7404	NOT	6	1	7427	NOR	3	3

# Logic Gates (5)

- CMOS Logic Gates
  - Signal levels

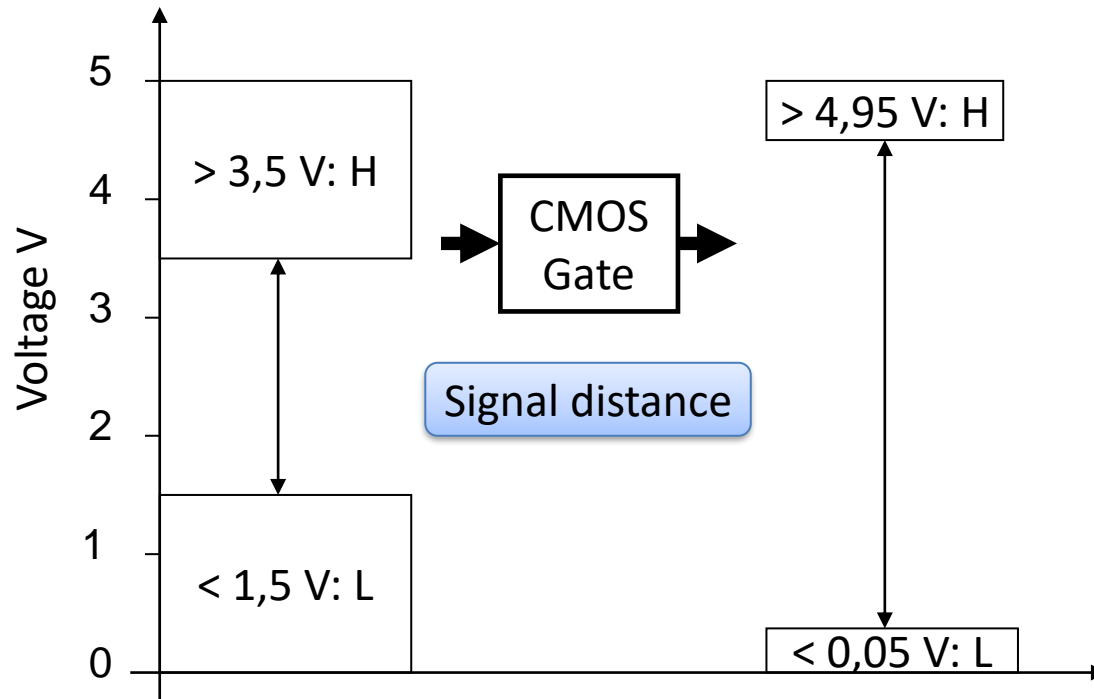

# Logic Gates (6)

- CMOS Logic Gates (continued)

- CMOS gates are found in the 4000 series

IC	Gate	Number	Lines	IC	Gate	Number	Lines
4081	AND	4	2	4011	NAND	4	2
4073	AND	3	3	4023	NAND	3	3
4082	AND	2	4	4012	NAND	2	4
4071	OR	4	2	4001	NOR	4	2
4049	NOT	6	1	4025	NOR	3	3

- There are also CMOS version of the TTL gates

- 74HC00: CMOS compatible voltage levels
    - 74HCT00: TTL compatible voltage levels

# Logic Gates (7)

- 7404: Hex inverter

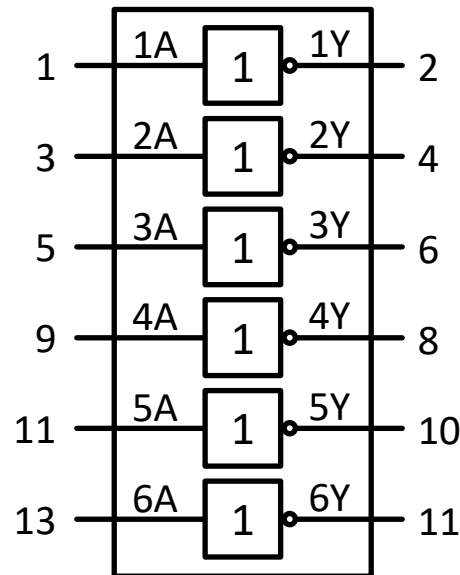

Functional Diagram

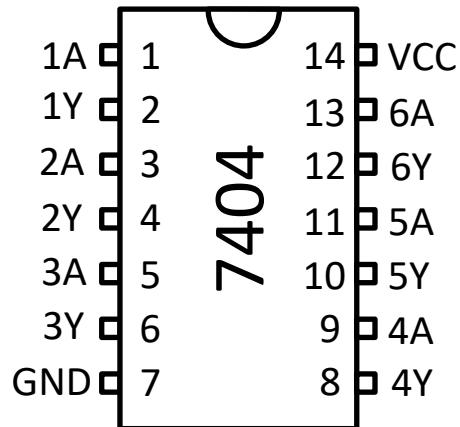

Pin Configuration

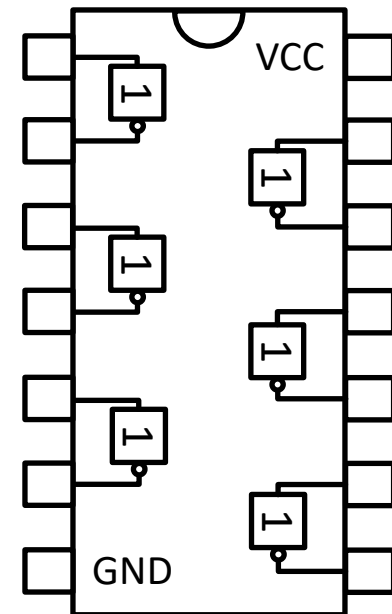

Internal View



# Logic Gates (8)

- 7408: Quad 2-input AND gate

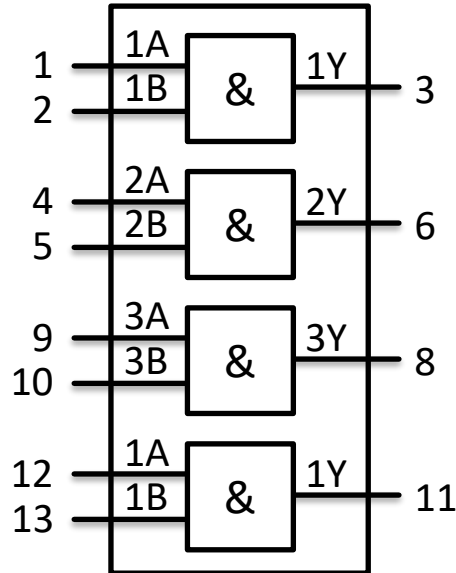

Functional Diagram

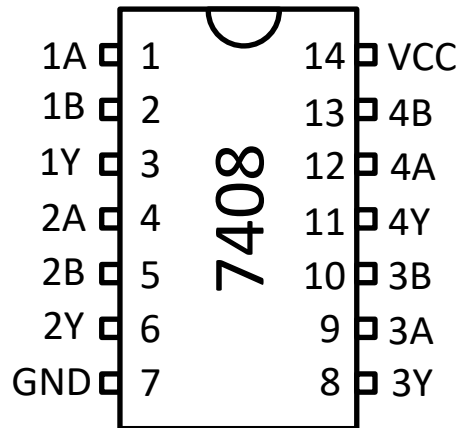

Pin Configuration

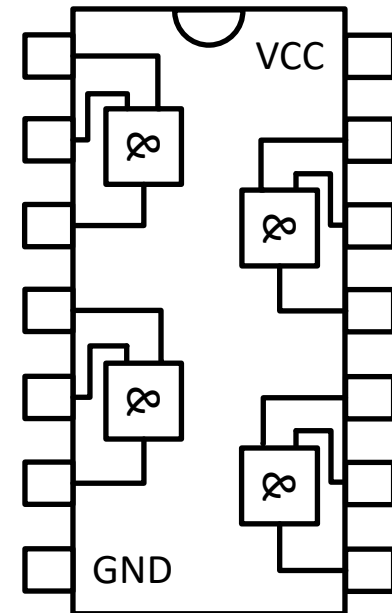

Internal View

# Logic Gates (9)

- 7432: Quad 2-input OR gate

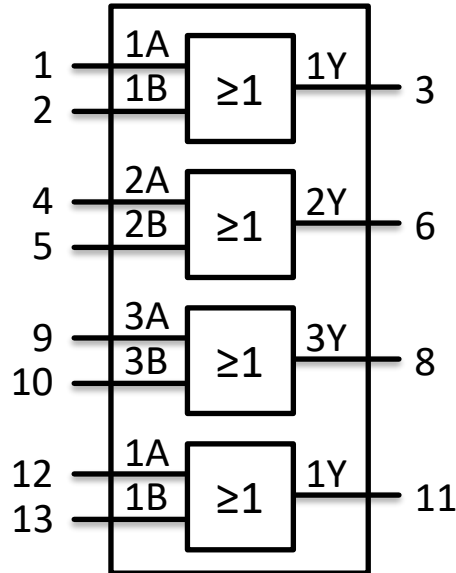

Functional Diagram

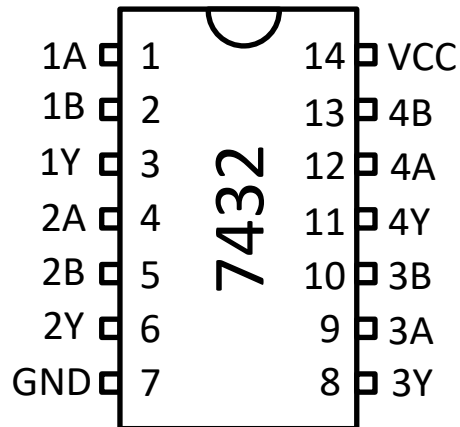

Pin Configuration

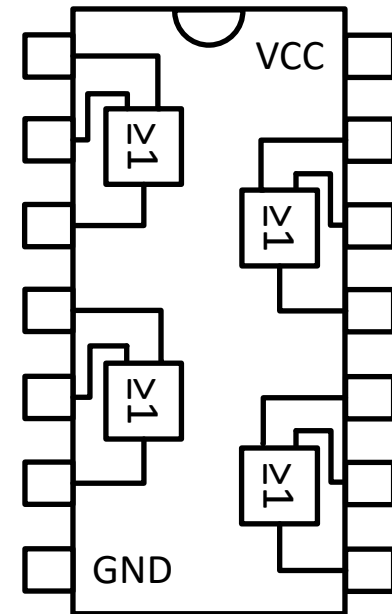

Internal View

# Logic Gates (10)

- 7486: Quad 2-input XOR gate

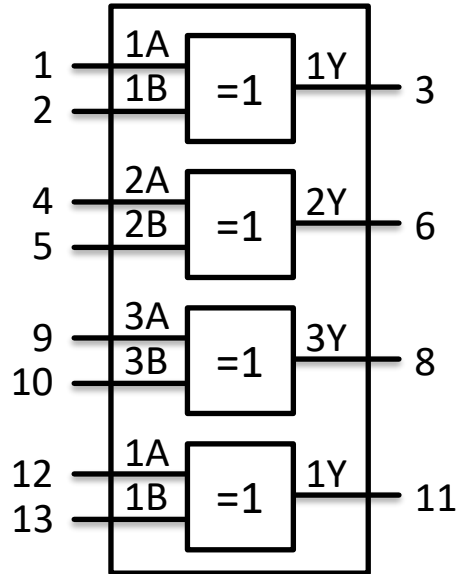

Functional Diagram

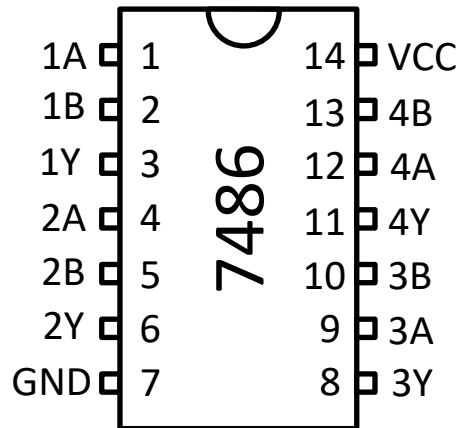

Pin Configuration

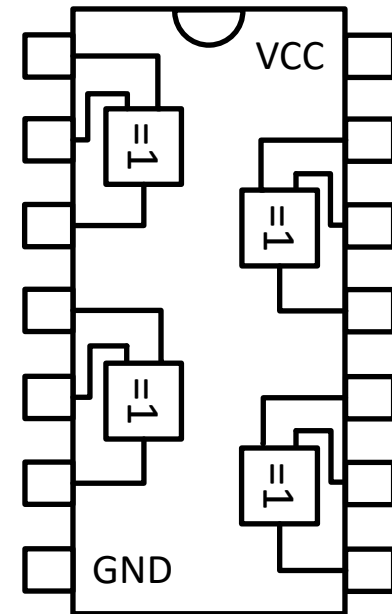

Internal View