

Displays

Networks and Embedded Software

Module 4.2.2

by Wolfgang Neff

Indicator Lamps (1)

- Indicates information
 - Lamp itself has no information
 - Information comes from context



Okay



Error

Function
Indicator

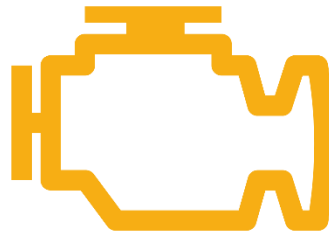

Engine Malfunction
Indicator Lamp



Third floor



Second floor



First floor

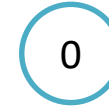

Basement floor

Elevator Floor
Indicator

Indicator Lamps (2)

- Light-Emitting Diodes
 - Switched on or off by control pin
 - Two operation
 - Active high (on = 1)
 - Active low (on = 0)

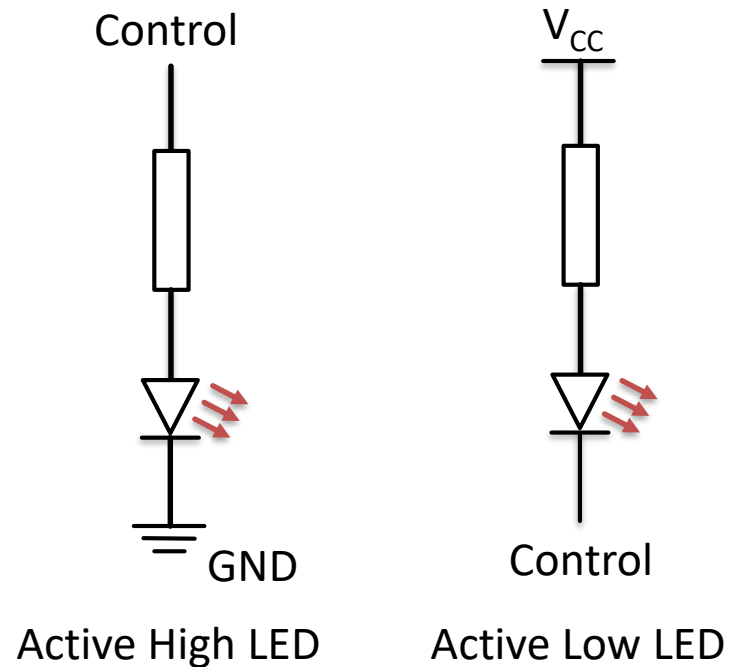

Indicator Lamps (3)

- LEDs can be combined
 - Common Cathode
 - Active High
 - Common Anode
 - Active Low

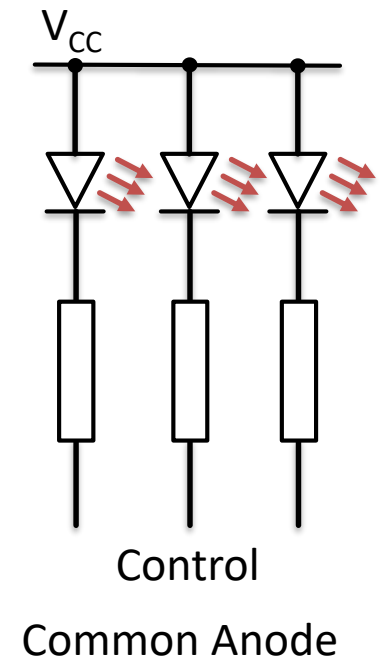
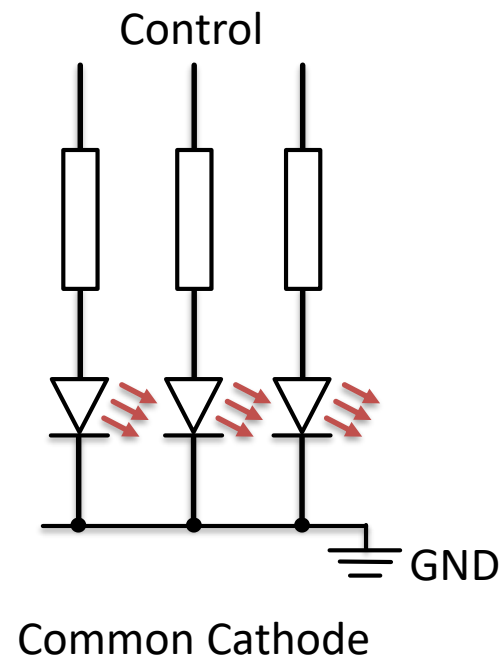
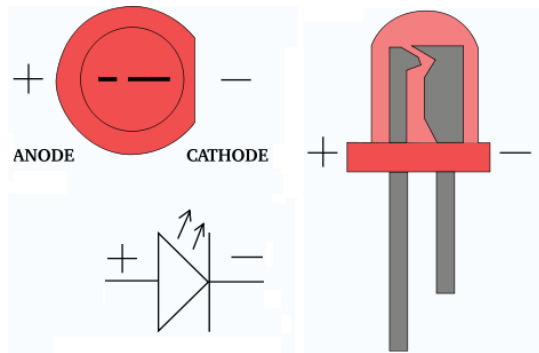

Seven-Segment Displays (1)

- Mode of Operation
 - Seven segments display a number

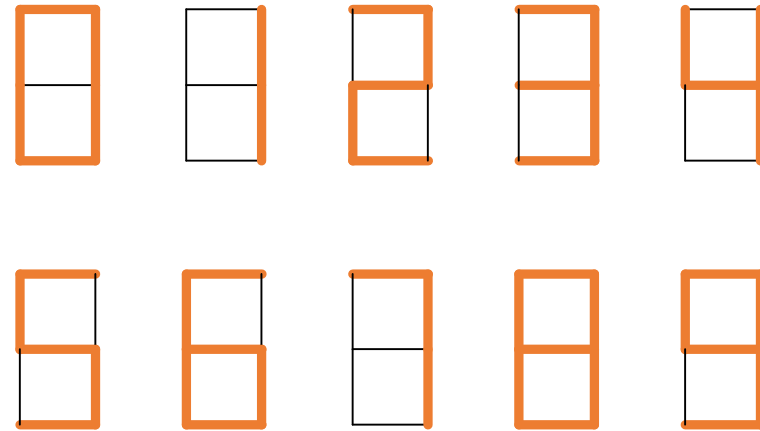
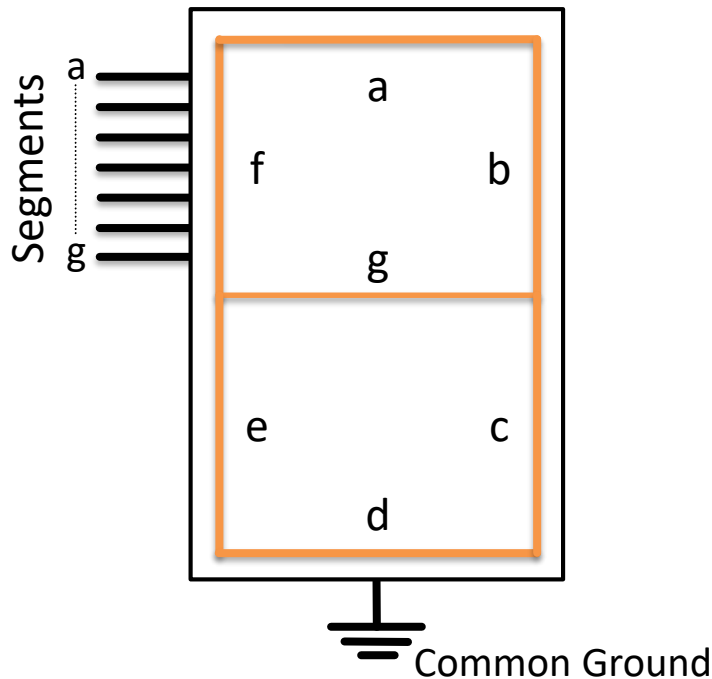

Number Representation

Seven-Segment Displays (2)

- Seven-Segment Driver

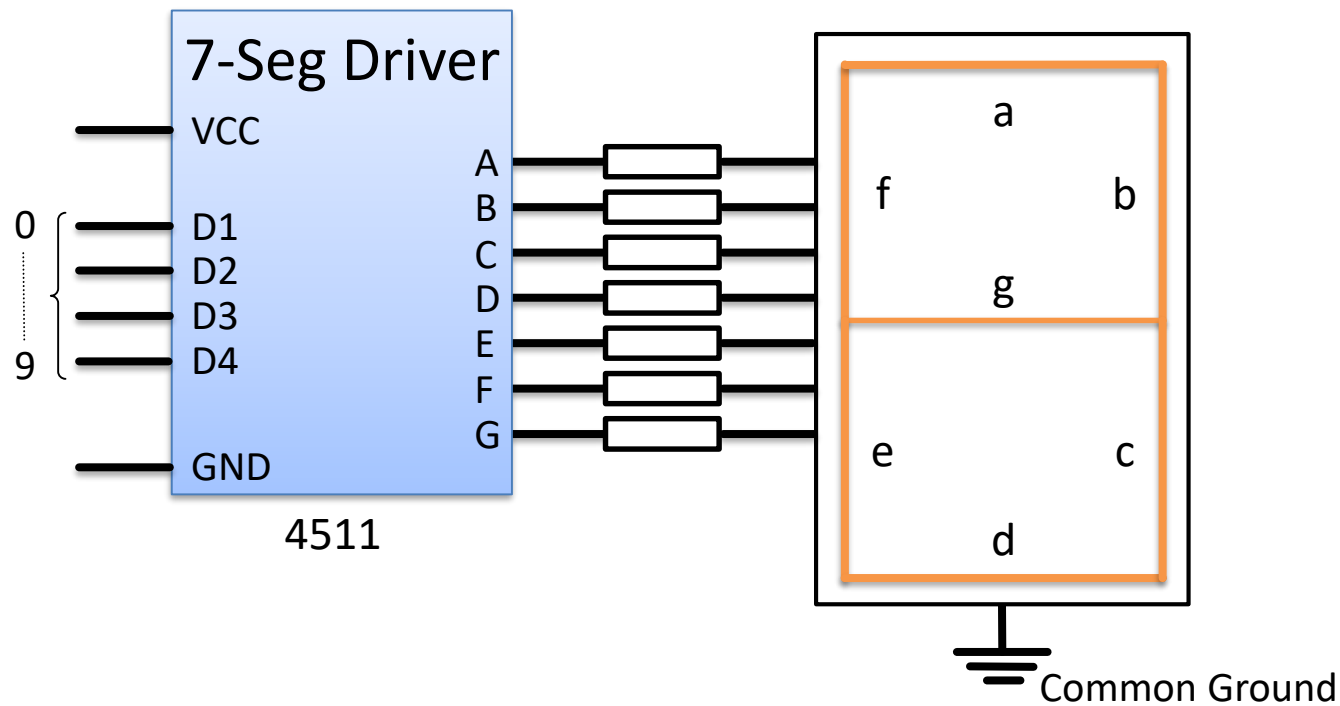

Dot-Matrix Displays (1)

- LEDs arranged in a block

– Arranged in

- Columns
- Rows

– Example

- 8×8 dot-matrix 

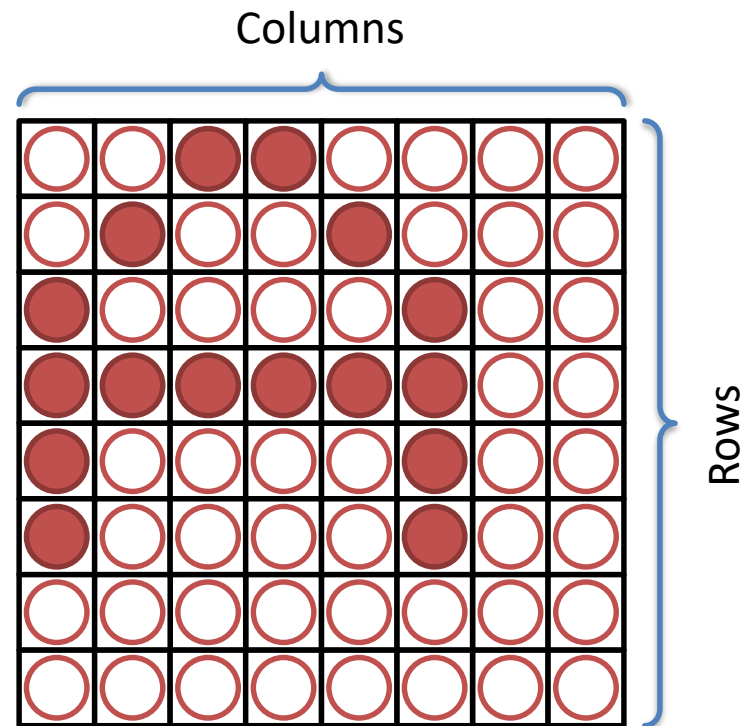

Dot-Matrix Displays (2)

- Electrical Setup

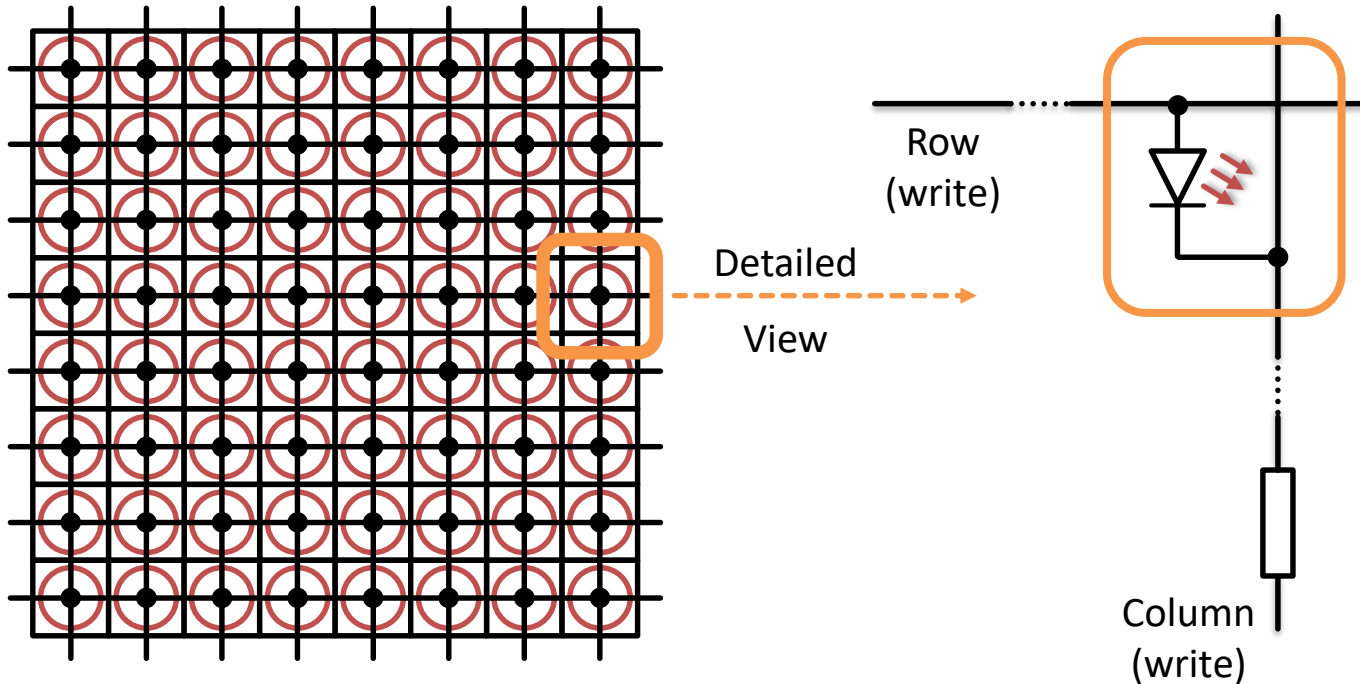

Dot-Matrix Displays (3)

- Dot-Matrix Controller

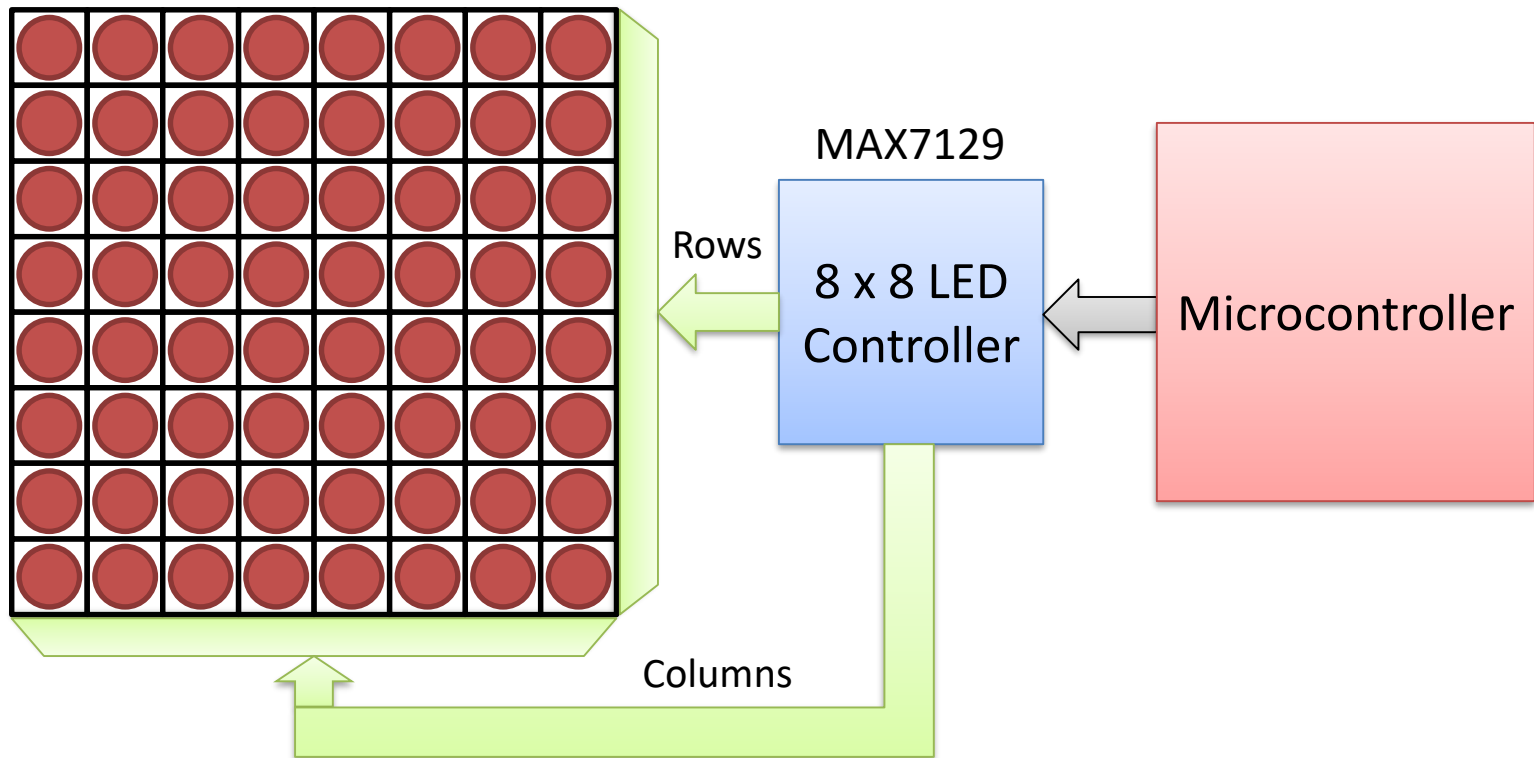

Liquid-Crystal Display (1)

- Functional Principle

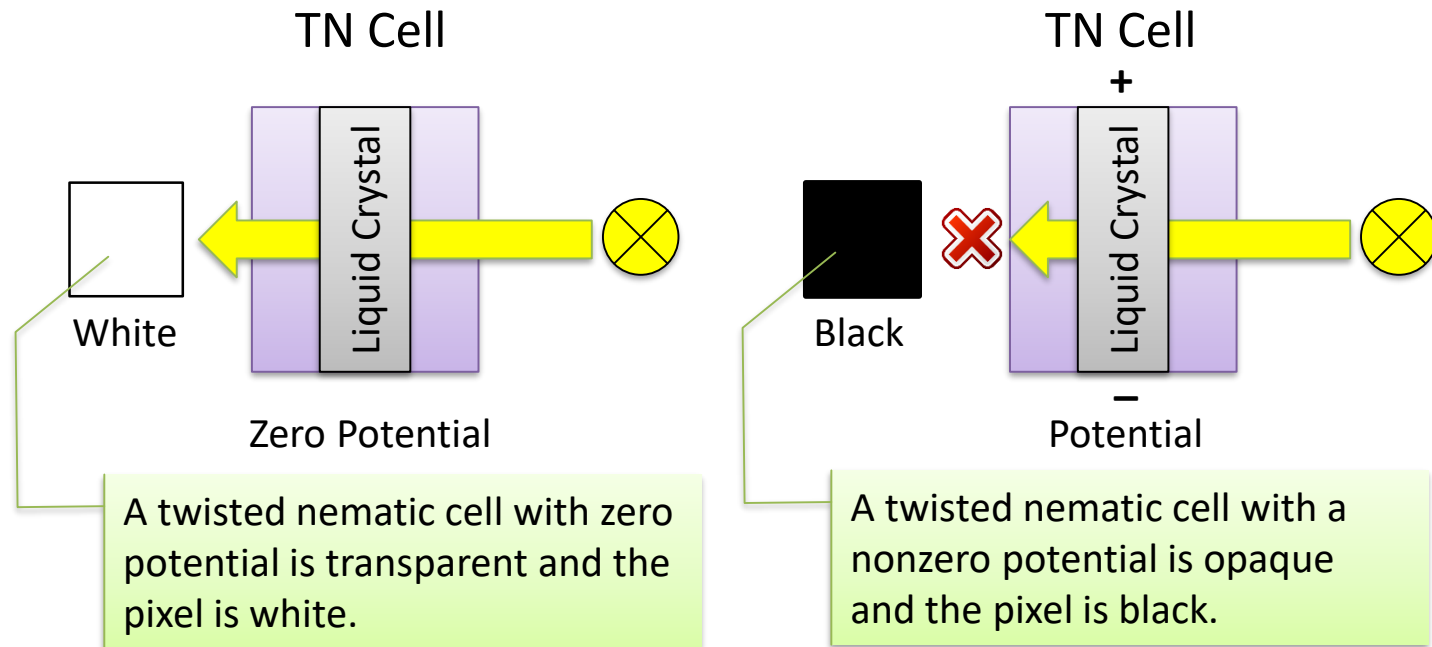

Liquid-Crystal Display (2)

- LCD Controller

