

Shift Registers

Networks and Embedded Systems

First Grade Level

Wolfgang Neff

Serial and Parallel (1)

- Parallel vs. Serial
 - Bits can come in parallel or in series
 - Parallel: all at a time, a group of bits
 - Serial: one after another, a series of bits

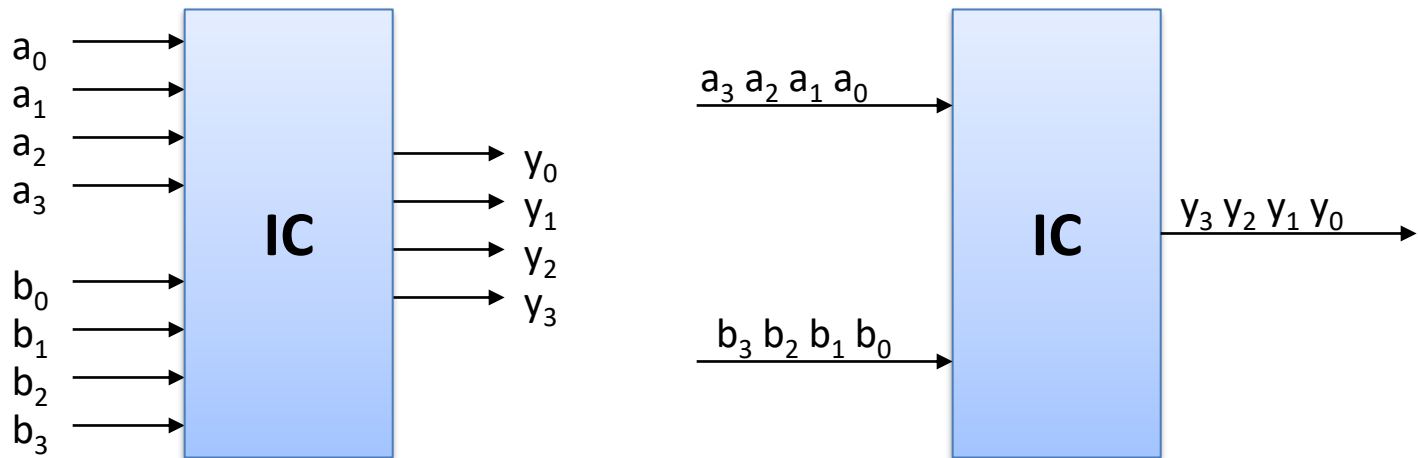

Serial and Parallel (2)

- MSB or LSB First
 - Bits can come in different orders
 - Most significant bit (MSB) first
 - Least significant bit (LSB) first

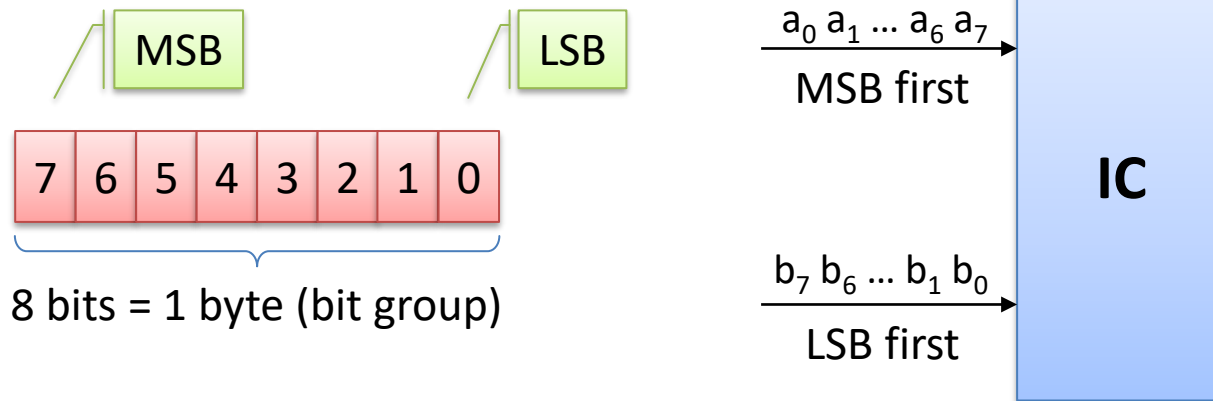

Serial and Parallel (3)

- Converter
 - Serial-to-parallel converter
 - A series of bits is converted into a bit group
 - Parallel-to-serial converter
 - A bit group is converted into a series of bits

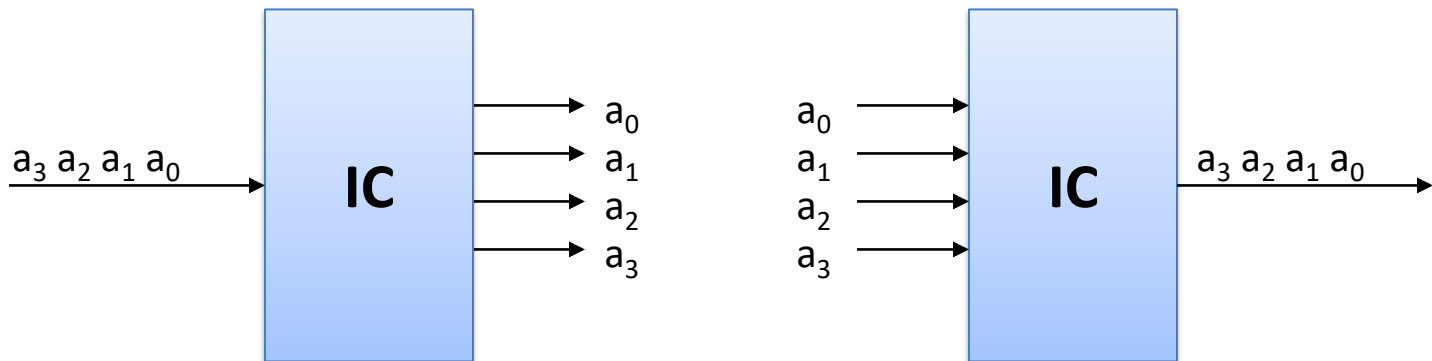

Serial and Parallel (4)

- Serial-to-Parallel Converter
 - Implementation
 - Shift register
 - Data is shifted in
 - Register gets filled

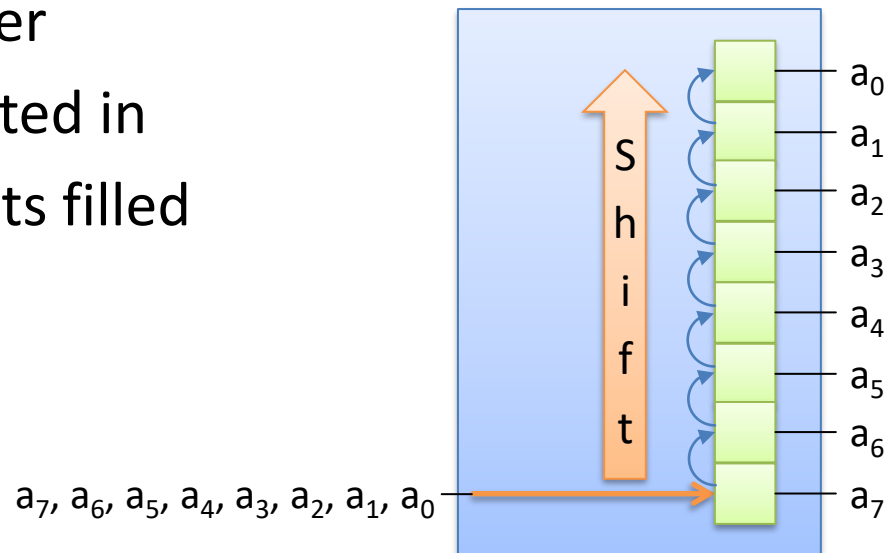

Serial and Parallel (5)

- Parallel-to-Serial Converter

- Implementation

- Shift register
 - Data is shifted out
 - Register gets empty

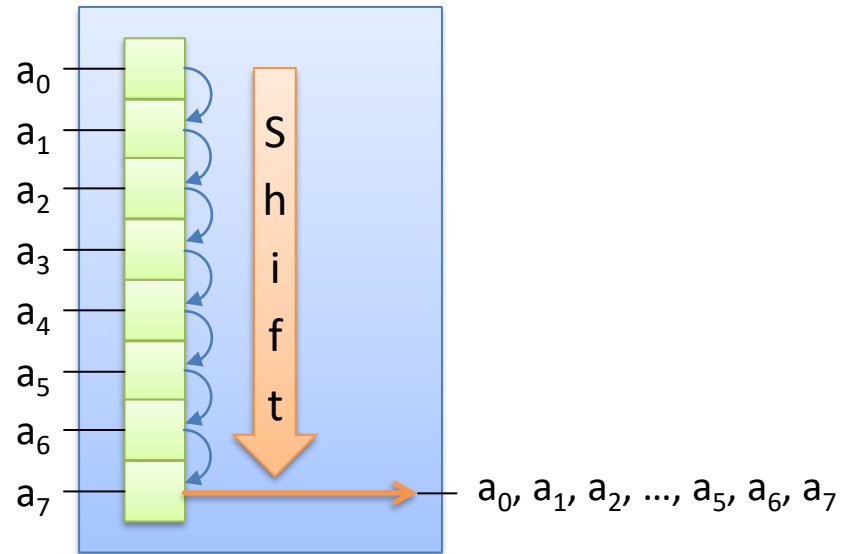

Shift Registers (1)

- Mode of Operation
 - Serial in (SI), Data in (DIN, DI)
 - Serial out (SO)
 - Parallel out (Q_i)
 - Clock (CLK)

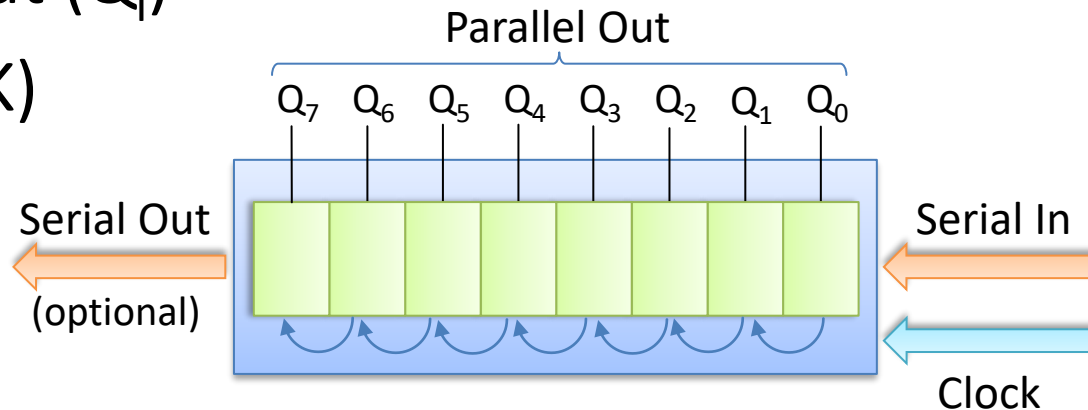

Shift Registers (2)

- Mode of Operation (continued)

- Implementation

- D flip-flops
- Daisy chain
- Common clock

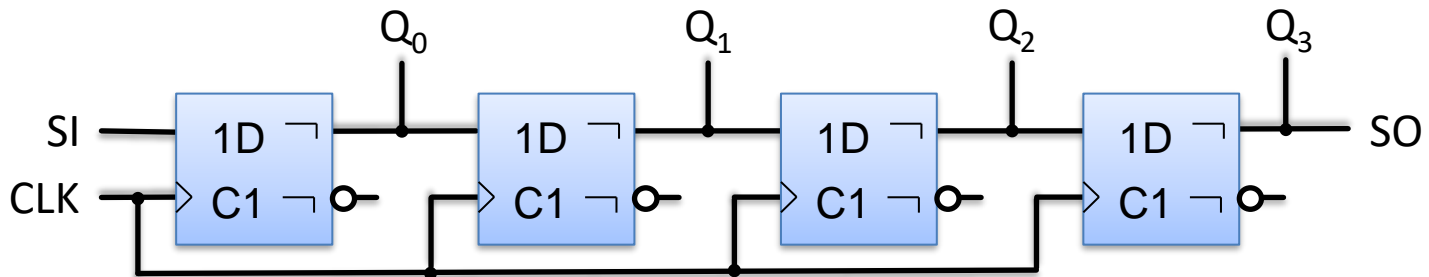

Shift Registers (3)

- Mode of Operation (finished)
 - Demonstration: shifting a bit

Tick	SI	CLK	Q ₀	Q ₁	Q ₂	Q ₃	SO
0	0	↑	0	0	0	0	0
1	1	↑	0	0	0	0	0
2	0	↑	1	0	0	0	0
3	0	↑	0	1	0	0	0
4	0	↑	0	0	1	0	0
5	0	↑	0	0	0	1	0
6	0	↑	0	0	0	0	1
7	0	↑	0	0	0	0	0

Shift Registers (4)

- Output Latches
 - Hide the process of shifting
 - Strobe activates latches

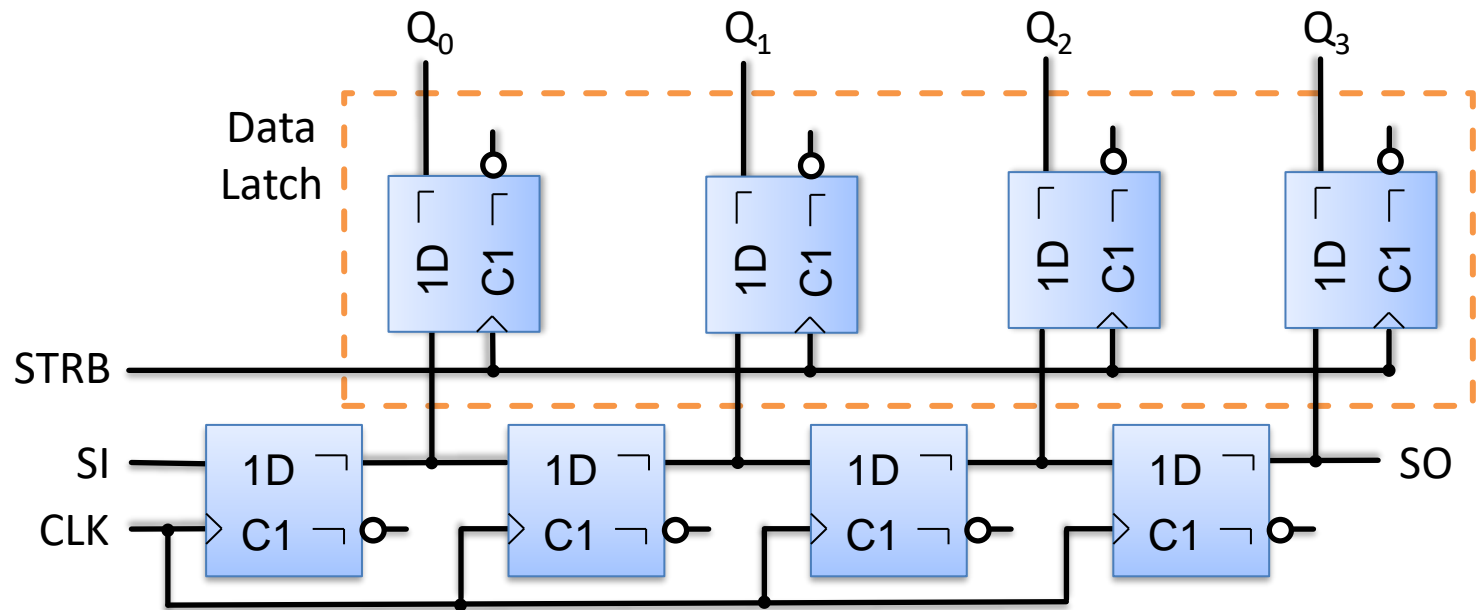

Shift Registers (5)

- 74595 – 8-bit serial-in shift register

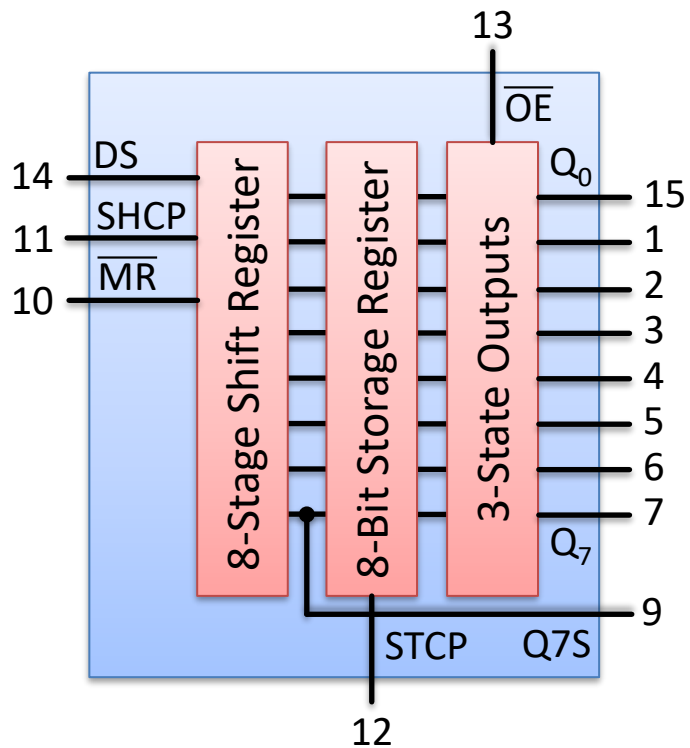

Block Diagram

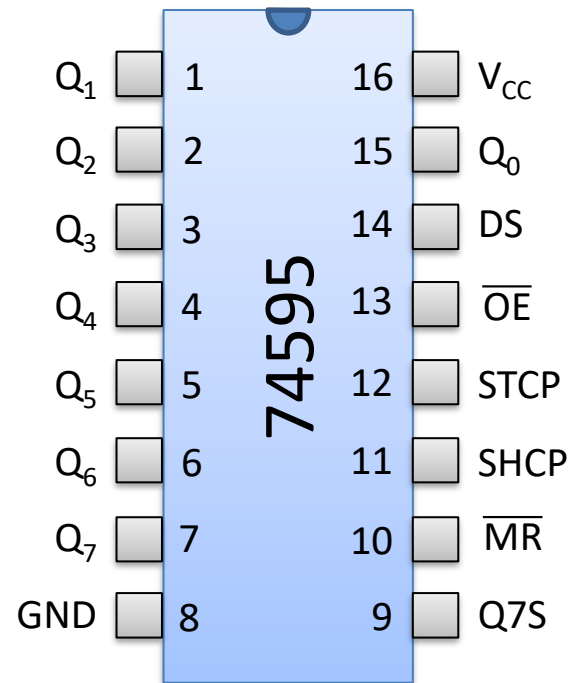

Pin Configuration

Shift Registers (6)

- 74595 – 8-bit serial-in shift register (continued)

Symbol	Pin	Description
Q0, Q1, Q2, Q3, Q4, Q5, Q6, Q7	15, 1, 2, 3, 4, 5, 6, 7	parallel data output
GND	8	ground (0 V)
Q7S	9	serial data output
$\overline{\text{MR}}$	10	master reset
SHCP	11	shift register clock input
STCP	12	storage register clock input
$\overline{\text{OE}}$	13	output enable input
DS	14	serial data input
V _{CC}	16	supply voltage

Shift Registers (7)

- 74595 – 8-bit shift register; 3-state (finished)

State	Description	Meaning
L	Low voltage	Output: current source
H	High voltage	Output: current sink
Z	High Impedance	Off state, not connected

