

Microprocessor Systems

Networks and Embedded Systems

First Grade Level

Wolfgang Neff

Microprocessor Systems (1)

- Microprocessor System

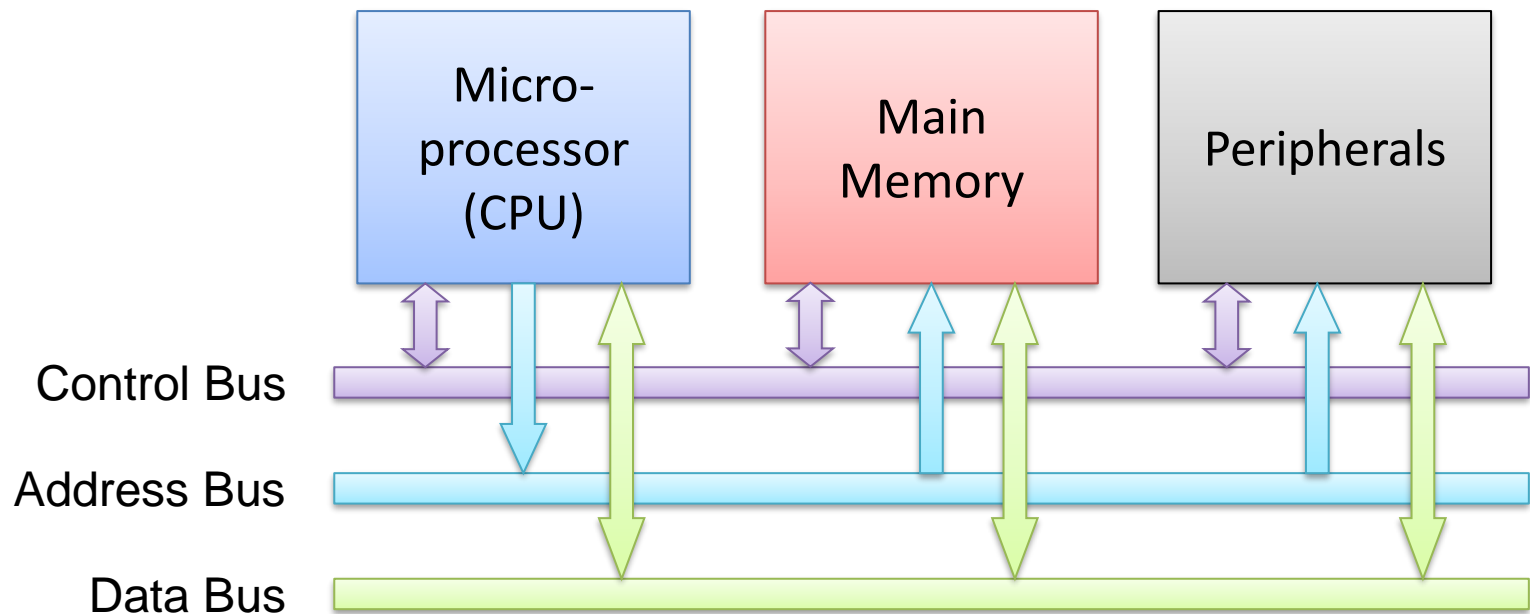

Microprocessor Systems (2)

- Microcontroller / System on a Chip (SoC)

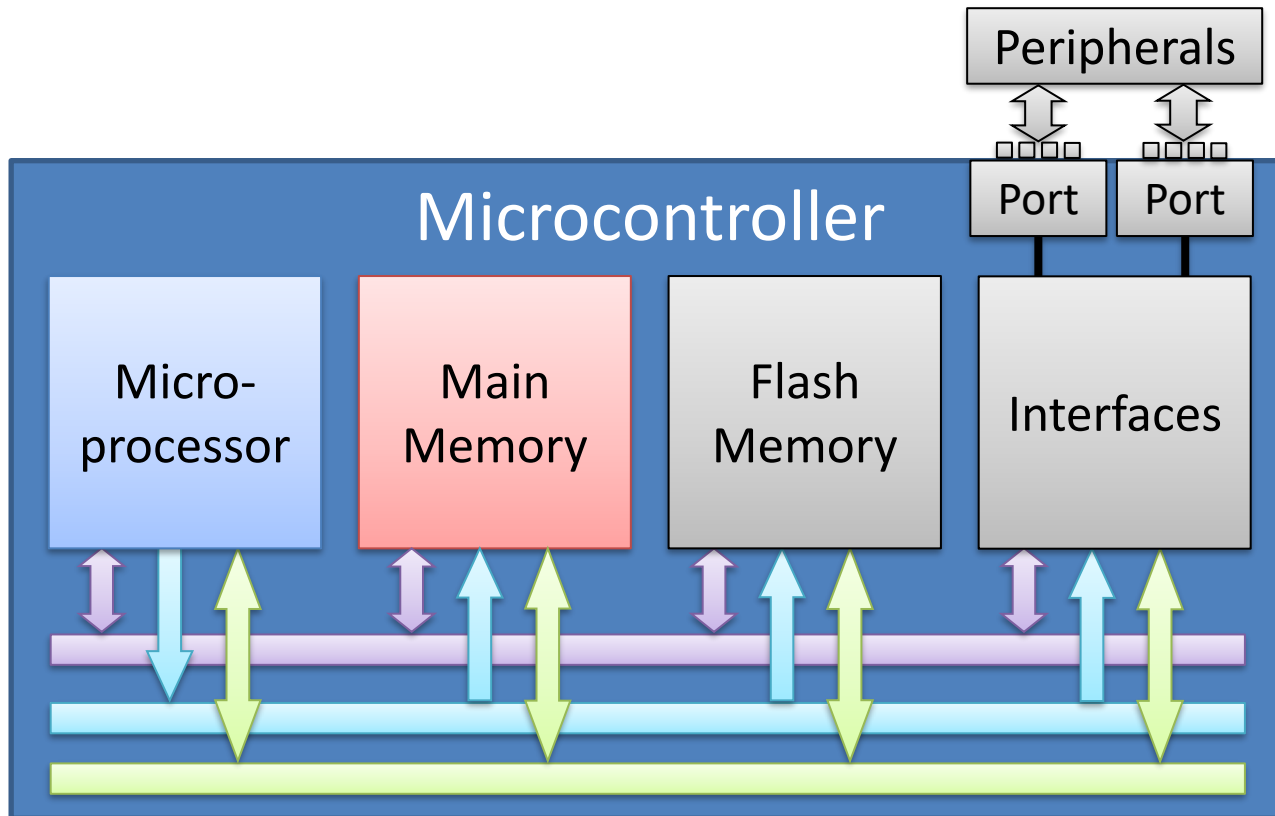

Microprocessor Systems (3)

- Microprocessor

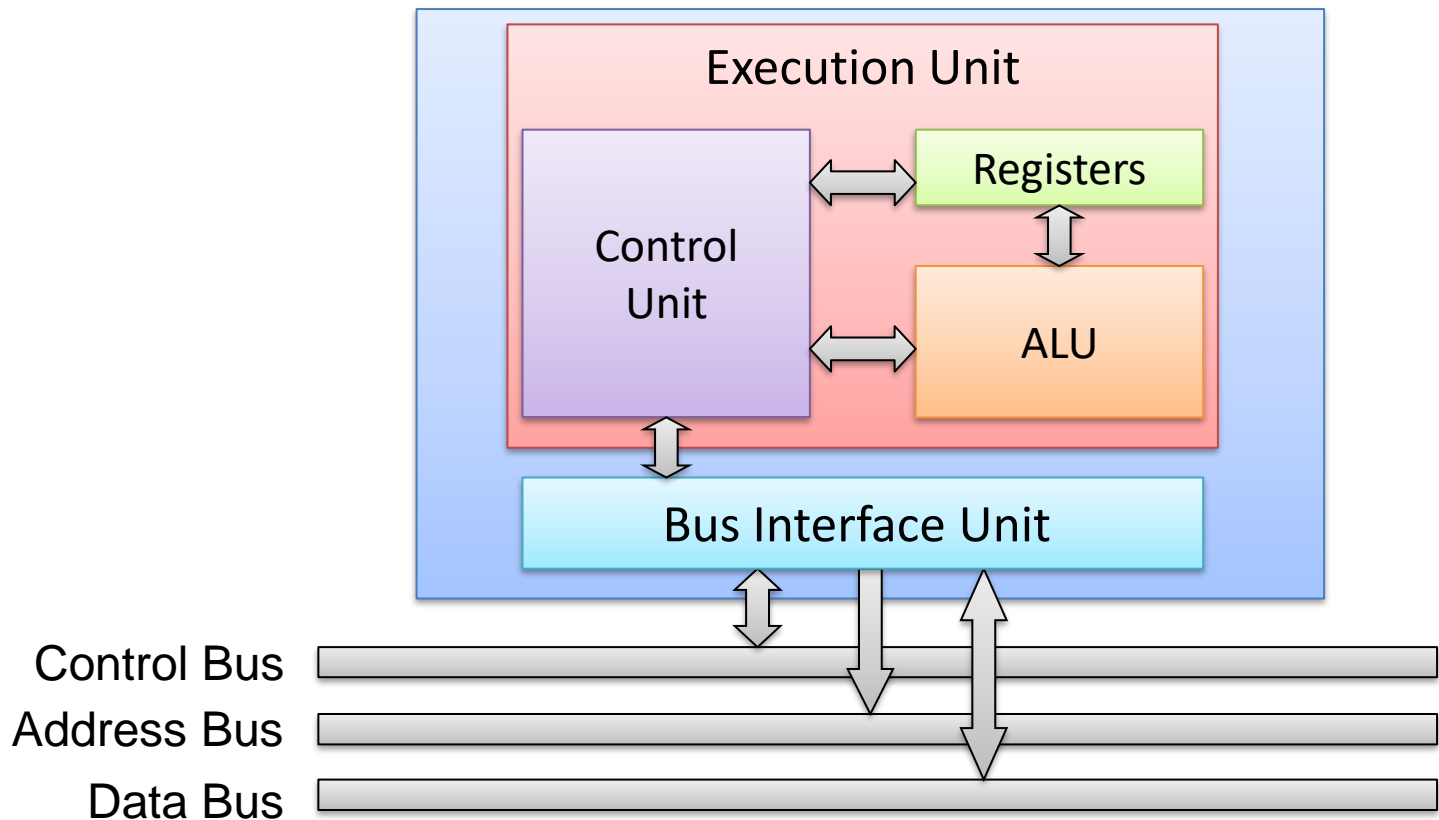

Microprocessor Systems (4)

- Information Flow

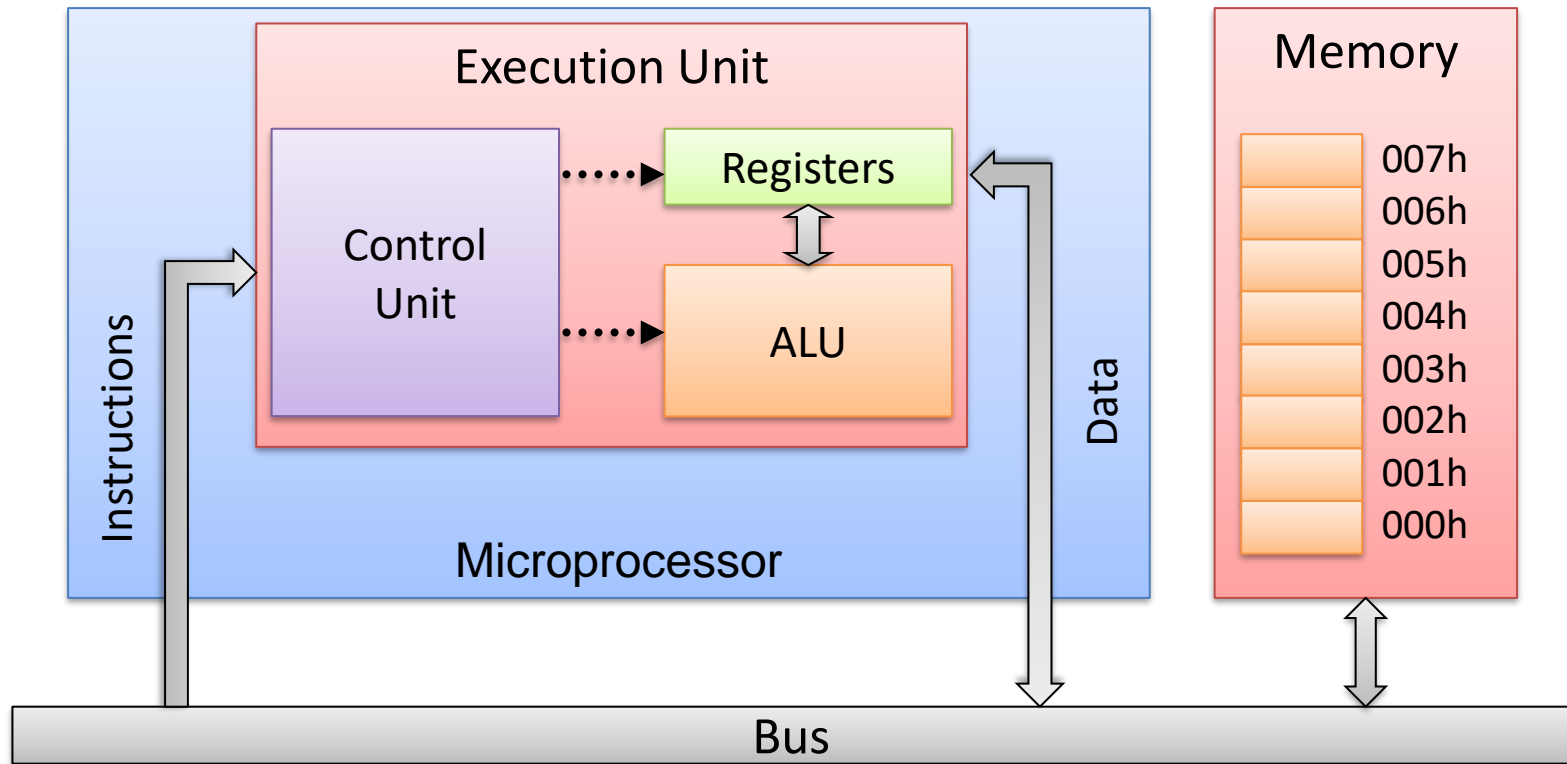

Memory (1)

- Memory Access

Compiler stuff
(not in storage)

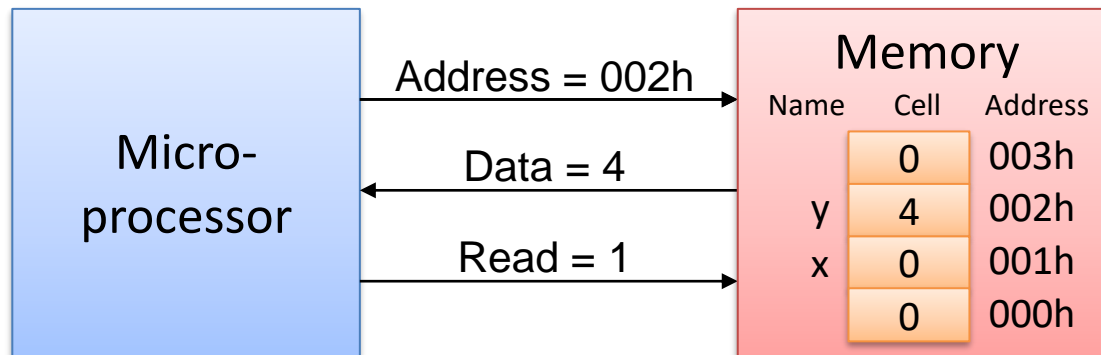
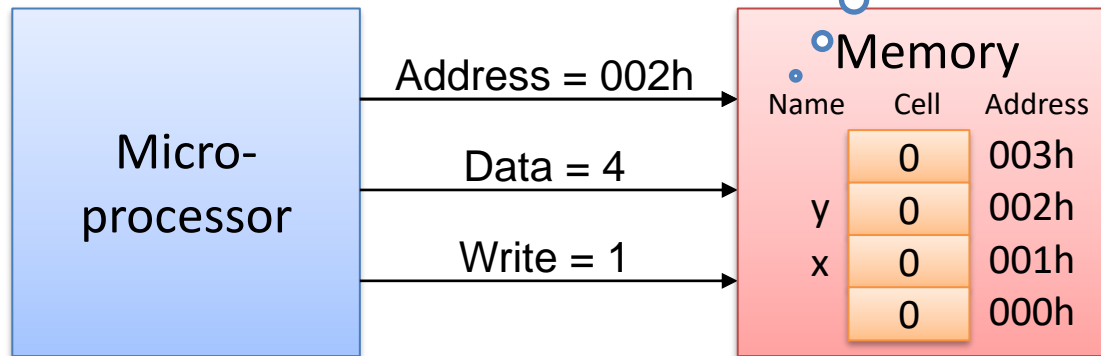

Memory (2)

- Memory Hierarchy

- Motto: the faster the smaller
- Data is copied between different hierarchies
- Heavily used data is close to the microprocessor

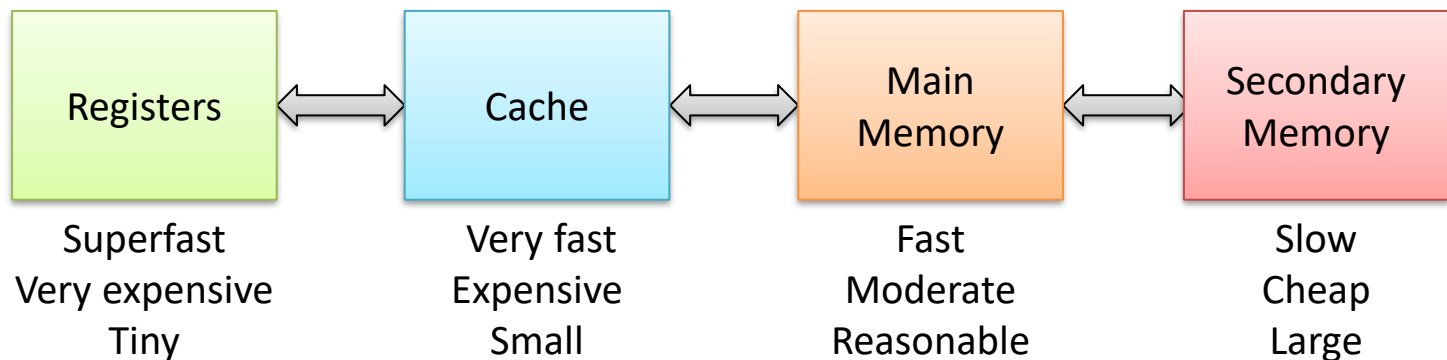

Peripherals (1)

- Examples

- Computers

- Storage: hard disk drive, SSD
 - Input devices: keyboard, mouse
 - Output devices: monitor, printer, speaker



- Mobile Phone

- Storage: flash, SD memory card
 - Input devices: touch screen, camera
 - Further devices: accelerometer, GPS



Peripherals (2)

- Characteristics
 - Independent devices
 - Have their own controller
 - Have their own register set
 - Data exchange necessary
 - Host/Device connection
 - Connected via interface
 - Operate asynchronously
 - Device acts independently from host



Peripherals (3)

- Architecture

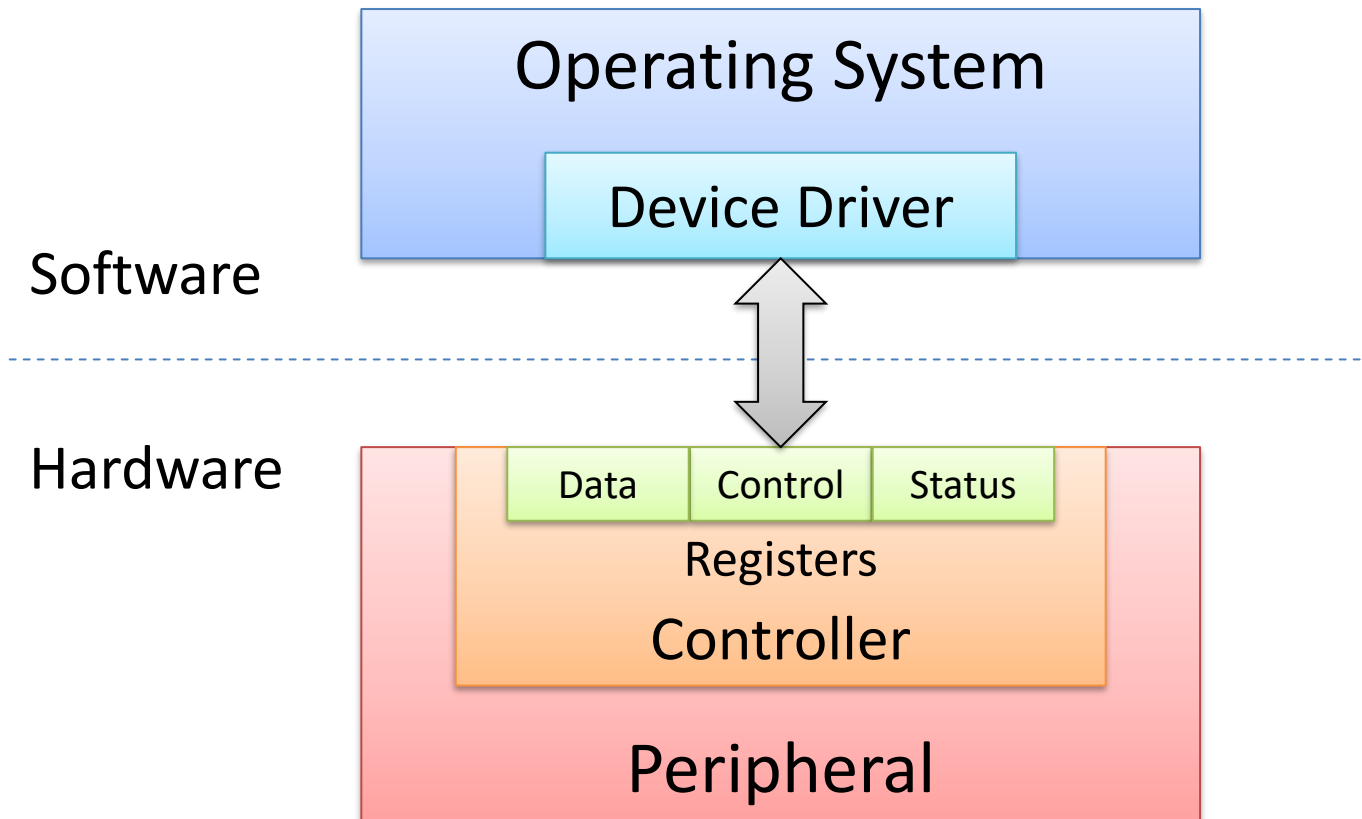

Peripherals (4)

- Register Set
 - Data Register
 - Used to transfer data to and from the device
Example: the text a printer should print
 - Control Register
 - Tells the device what to do
Example: print out a color copy
 - Status Register
 - Reports what the device is doing
Example: printer has stopped as it is out of paper

Peripherals (5)

- Communication

- Polling

- Device is polled if it is ready to receive data
 - Device is polled if new data is available

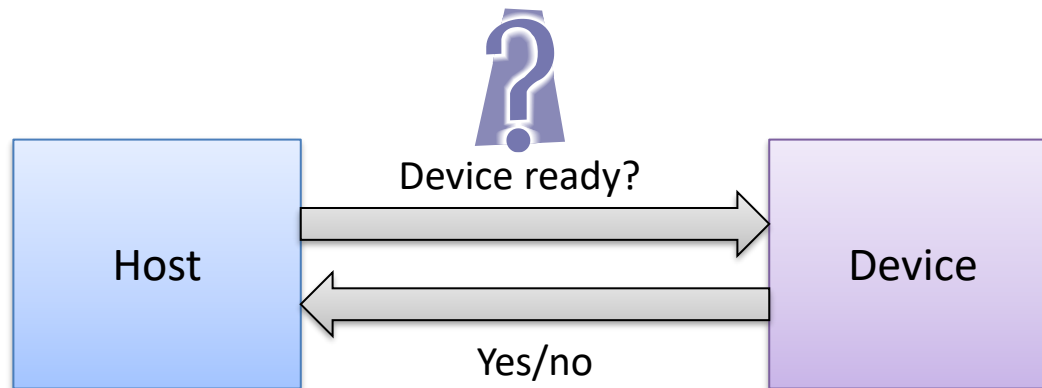

Peripherals (6)

- Communication (continued)
 - Interrupt
 - Device indicates that it is ready receive data
 - Device indicates that new data is available

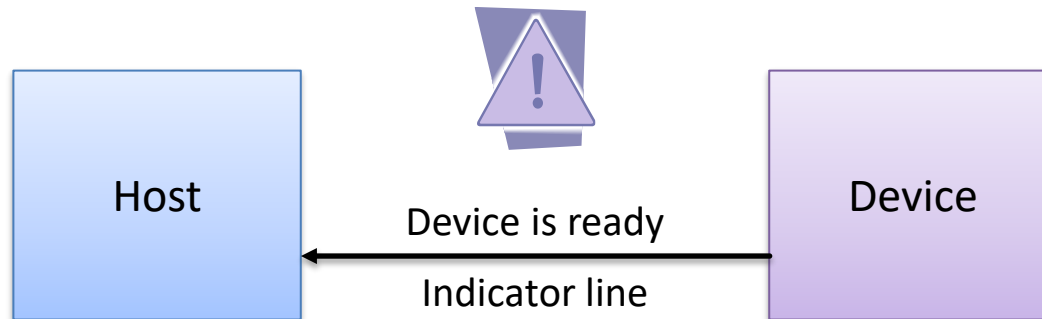

Development Boards (1)

- Basic Idea
 - Prototype board
 - Concept testing
 - Components
 - Microcontroller
 - Power supply
 - Pin breakout
 - Connection to Host
 - Status indicators

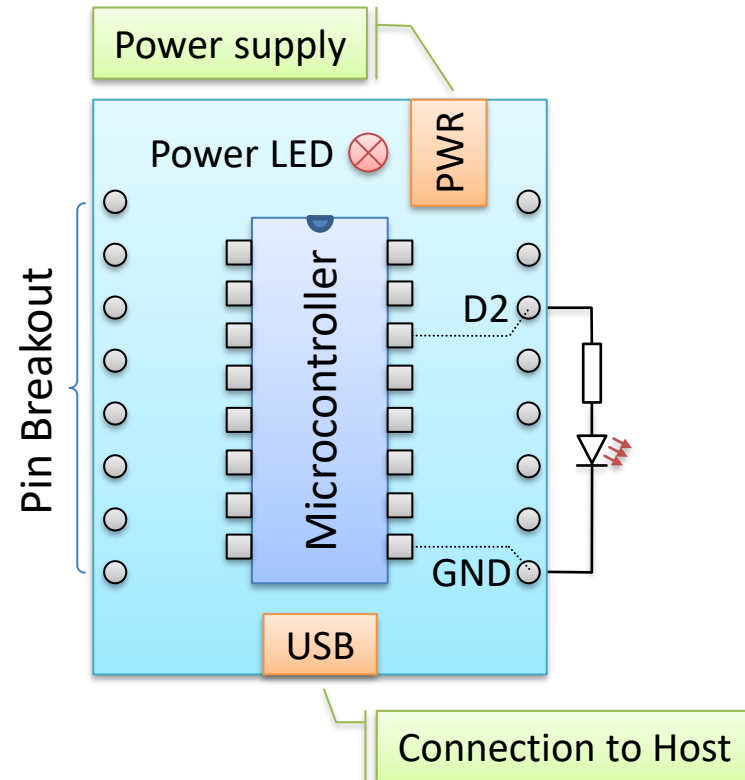

Development Boards (2)

- Example: DOIT Esp32 Devkit V1

