

Design of Sequential Circuits I

Please do the following exercises individually.

Bit sequences

Please design a sequential circuit which finds three subsequent 0s in a bit stream.

State machine and encoding

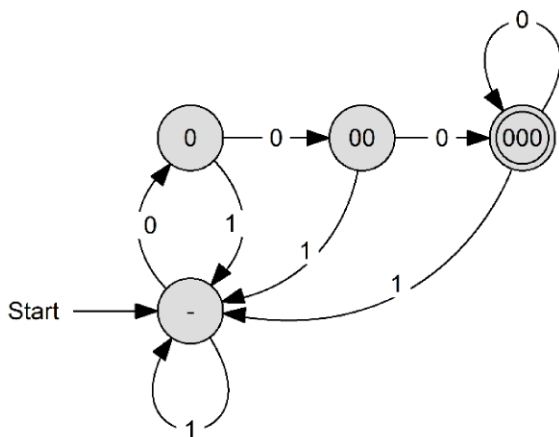

State	Encoding	
-	0 _{dec}	00 _{bin}
0	1 _{dec}	01 _{bin}
00	2 _{dec}	10 _{bin}
000	3 _{dec}	11 _{bin}

Two D flip-flops necessary

Control logic

Q ₁	Q ₀	a	Q ₁ ⁺	Q ₀ ⁺
0	0	0	0	1
0	0	1	0	0
0	1	0	1	0
0	1	1	0	0
1	0	0	1	1
1	0	1	0	0
1	1	0	1	1
1	1	1	0	0

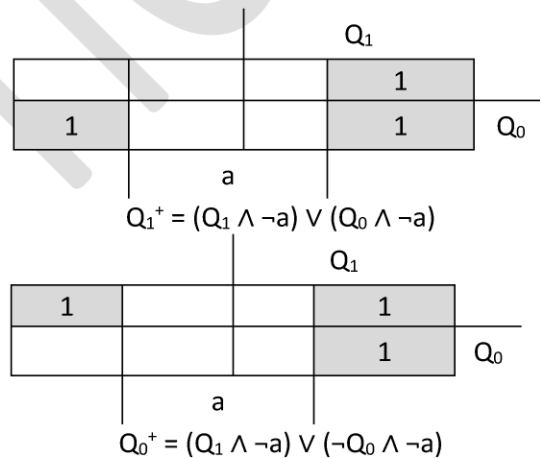

Output logic and circuit

Q ₁	Q ₀	y
0	0	0
0	1	0
1	0	0
1	1	1

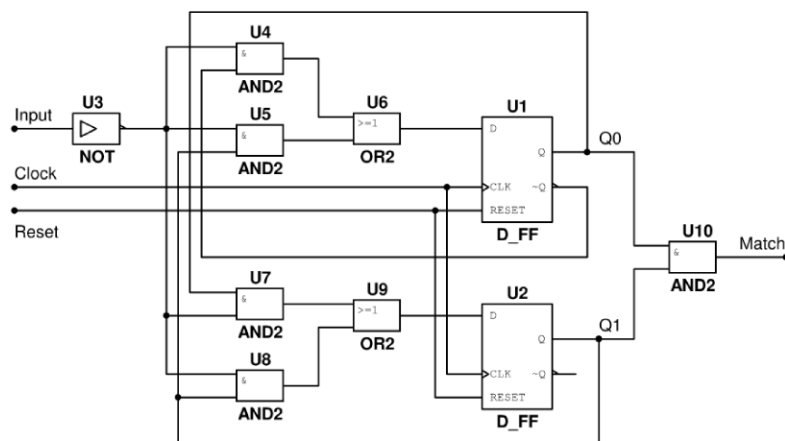
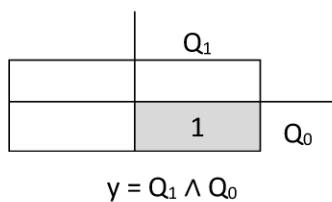

Design of Sequential Circuits II

Please do the following exercises individually.

Counter

Please design a mod-6 counter.

State machine

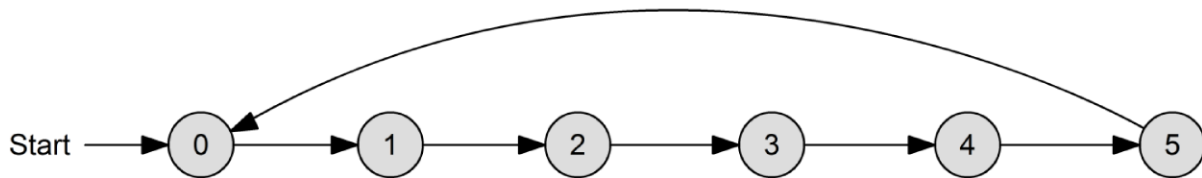

State encoding and output logic

State	0	1	2	3	4	5
Encoding	000	001	010	011	100	101

Three D flip-flops necessary
No output logic necessary

Control logic and circuit

n	Q_2	Q_1	Q_0	Q_2^+	Q_1^+	Q_0^+
0	0	0	0	0	0	1
1	0	0	1	0	1	0
2	0	1	0	0	1	1
3	0	1	1	1	0	0
4	1	0	0	1	0	1
5	1	0	1	0	0	0
6	1	1	0	X	X	X
7	1	1	1	X	X	X

